



Very Well Connected™

INSTALLATION INSTRUCTIONS

Product

Docking Station - Getac B300 USB 3.0

7160-0526-00 No RF

7160-0526-02 Dual RF

Revision

Rev. G

Form

INST-669

Printing Spec: PS-001

Compatible with 3rd, 4th and 5th generation B300 computers

- 3rd generation computer part number (B300-H) 52628417xxxx
- 4th generation computer part number (B300-G4) 52628540xxxx
 - Compatibility issues:
 - G4 does not support LAN
 - USB will downgrade to USB 2.0
- 5th generation computer part number (B300-G5) 52628591xxxx

Not compatible with 1st and 2nd generation computers

- 1st generation computer part number 52628144xxxx
- 2nd generation computer part number (B300-X) 52628317xxxx



**These instructions are for the docking station only. For instructions on features, set-up and operation of the B300 computer, please refer to the manuals provided by Getac with the computer.*

*** This docking station is designed to be used with a variety of Gamber-Johnson mounting systems. Installation instructions for other Gamber-Johnson products are provided with each individual product.*

IMPORTANT SAFETY INFORMATION for INSTALLERS

Safety is dependent on the proper installation and servicing of this docking station. It is important to read and follow all instructions before installing this product.

To properly install a Gamber-Johnson docking station you must have a good understanding of automotive electrical procedures and systems, along with proficiency in the installation and service of aftermarket vehicle equipment.

There are no adjustments required at any time of the electrical components within the docking station. ***Opening the power/port replication housing will void the product warranty.***

Product Mounting Disclaimer

Gamber-Johnson is not liable under any theory of contract or tort law for any loss, damage, personal injury, special, incidental or consequential damages for personal injury or other damage of any nature arising directly or indirectly as a result of the improper installation or use of its products in vehicle or any other application. In order to safely install and use Gamber-Johnson products full consideration of vehicle occupants, vehicle systems (i.e., the location of fuel lines, brakes lines, electrical, drive train or other systems), air-bags and other safety equipment is required. Gamber-Johnson specifically disclaims any responsibility for the improper use or installation of its products not consistent with the original vehicle manufactures specifications and recommendations, Gamber-Johnson product instruction sheets, or workmanship standards as endorsed through the Gamber-Johnson Certified Installer Program.

© Copyright 2017 Gamber-Johnson, LLC

If you need assistance or have questions, call Gamber-Johnson at 1-800-456-6868

Page 1 of 8

B300 USB 3.0 DOCKING STATION FEATURE IDENTIFICATION

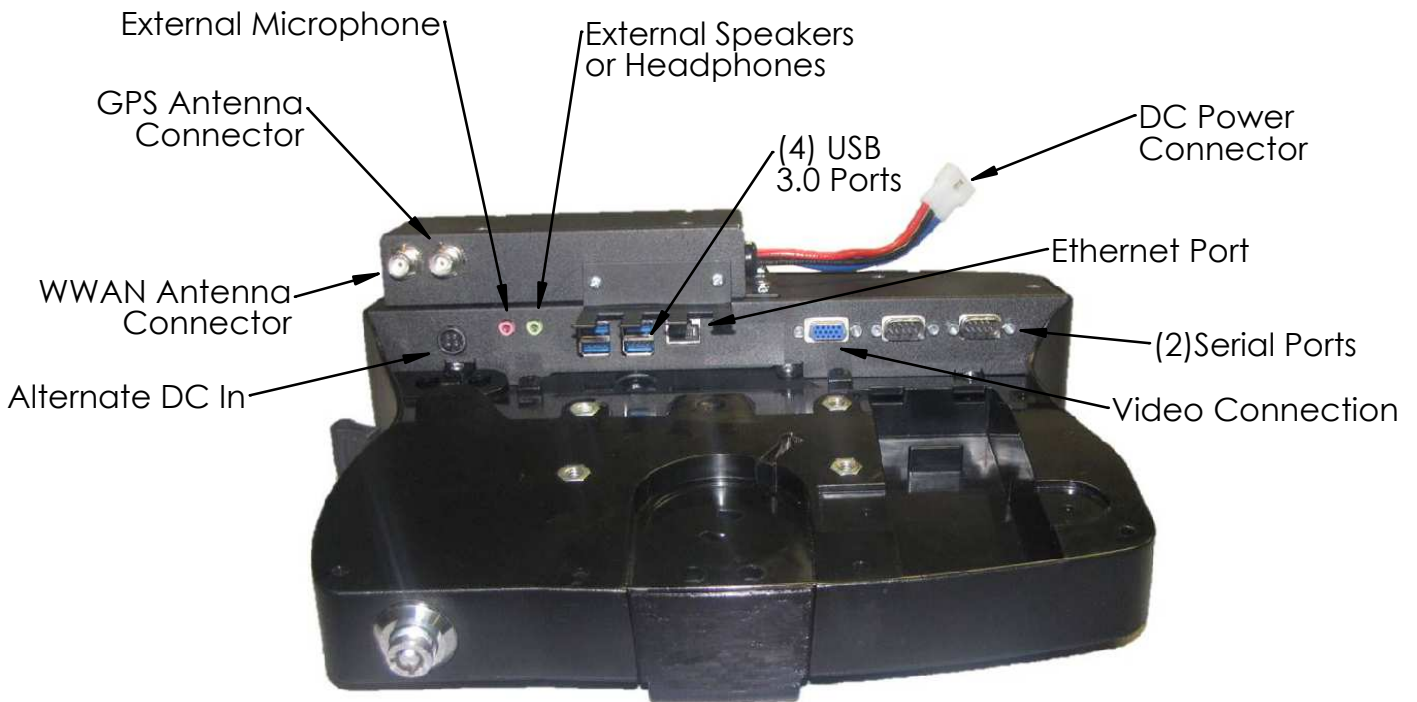
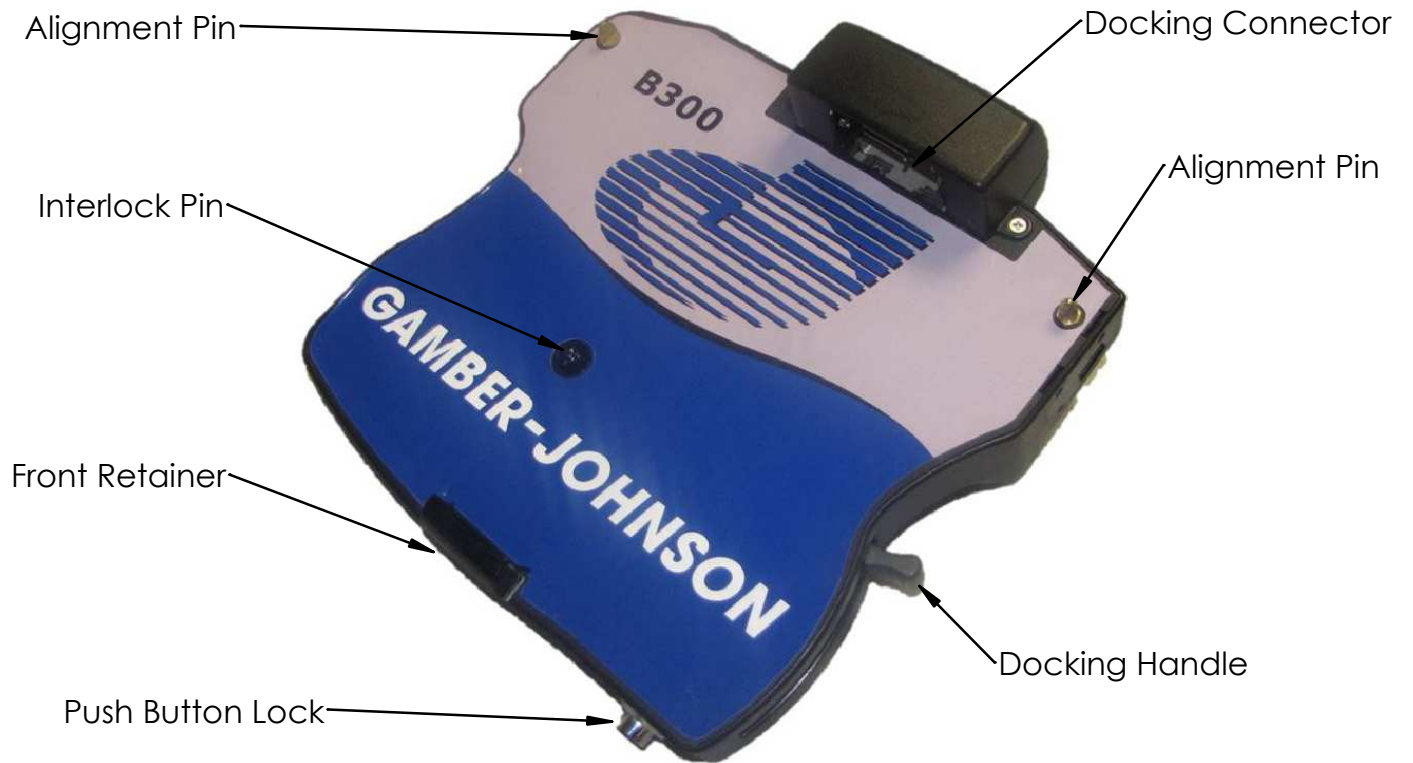

During Installation

- DO NOT connect this docking station to the vehicle battery until:
 1. ALL other electrical connections are made
 2. Mounting of ALL components are complete
 3. VERIFICATION that no shorts exist in the entire system
- DO NOT install equipment or route wiring or cords in the deployment path of any air bag.
- When drilling into the vehicle, DO make sure that both sides of the surface are clear of anything that could be damaged.

CAUTION: If wiring is shorted to the frame, high current conductors can cause hazardous sparks resulting in electrical fires or flying molten metal.

After Installation

- Test the docking station to ensure that it is working properly.

File these instructions in a safe place and refer to them when performing maintenance or re-installing.

WARNING: Failure to follow all safety precautions and instructions may result in property damage, serious injury or death.

PRE-INSTALLATION RECOMMENDATIONS

Conduct a "Bench Test"

Gamber-Johnson strongly advises a "bench test" be conducted to verify that all electronic and software issues are resolved prior to installation:

1. Make sure computer is operational by itself.
2. Insert computer into docking station and verify that the computer is operating in the dock.
3. Interconnect entire assembly and verify start-up of all components, including other equipment (printers, modems, scanners, etc.).

**Gamber-Johnson also recommends positioning of all mounts and equipment in the vehicle prior to the actual install to verify that mounting locations are safe and practical.*

POWER SWITCH

This docking station has a power switch with an LED light (see Figure 1):

- "INPUT POWER" - The green LED light, built into the power switch, indicates that there is power to the unit.
 - Standard Installation - In this set-up, the power switch can be turned on and off to regulate power through the unit.
 - By-Pass Installation - In this set-up, the unit is continuously powered (bypassing the power switch) and the green LED light is lit regardless of switch position.

**Refer to the Power Supply and Wiring Instructions sections of this manual for further information regarding these features.*

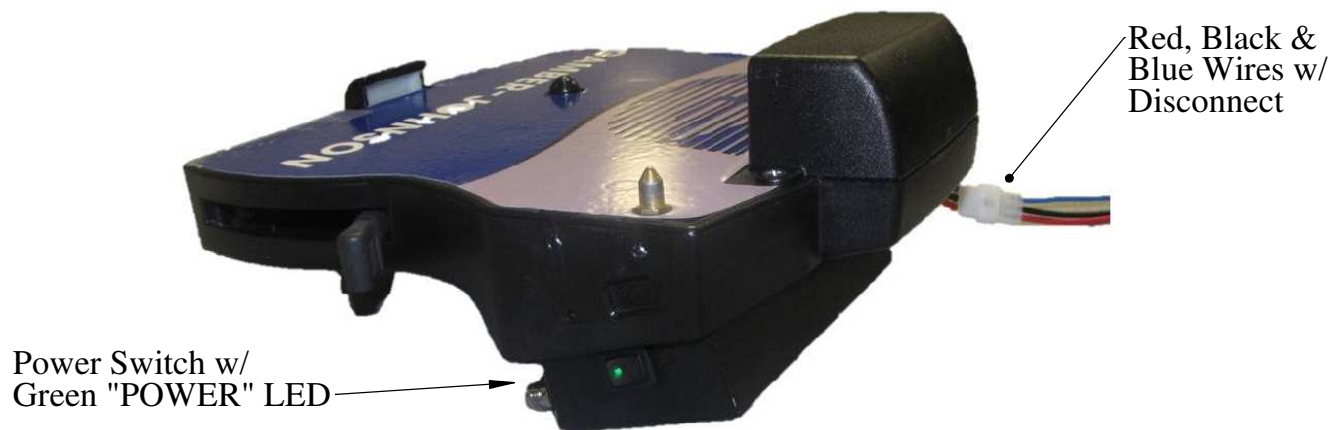

Figure 1

POWER SUPPLY INFORMATION

This docking station has a built-in power supply and is designed to be used with an 11 - 28 volt DC system. The voltage output is factory set at 19 volts.

Power is provided using the wires located on the underside of the docking station:

- Standard Installation - Use the RED and BLACK wires to utilize the power switch on the docking station, regulating power through the unit.
- By-Pass Installation - Use the BLUE and BLACK wires to continuously power the docking station and bypass the power switch.

WIRING INSTRUCTIONS

IMPORTANT: *Make sure that you have read this entire section before you begin wiring!*

Refer to Figure 2

1. Install docking station into vehicle, making sure that all bolts are tight.
2. Attach BLACK ground wire to the location where the vehicle battery grounds to vehicle chassis.
 - a. Standard Installation (Power switch is operational) - Connect the RED wire to the supply voltage (V+) from the vehicle. (The BLUE wire remains unconnected)
 - b. By-Pass Installation (Power switch is by-passed) - Connect the BLUE wire to the supply voltage (V+) from the vehicle. (The RED wire remains unconnected)

IMPORTANT REMINDERS:

- Use only SAE J1128 Type GPT number 14 AWG stranded wire (minimum) to attach the docking station to the vehicle's electrical system.
- Connect lead wires to the disconnect pigtail using the butt splice connectors provided with the docking station. *Caution: The butt splice connections must be made as close to the docking station as possible using the disconnect pigtail provided with the docking station. The disconnect must be easily accessible. When assembling the butt splice connectors use only Panduit crimp tools CT-100, CT-600, CT-1525 CT-1550 OR CT-1551. Using the wire joint provided with the docking station, cap the un-used RED or BLUE wire on the disconnect pigtail. Use only Panduit crimp tool CT-1550 or CT-1551.*
- Route the lead wires to the battery. Total wire in the circuit must not exceed 30 feet and must conform to SAE standard J1128.
- Protect the lead wires from abrasion and chafing by using wire loom or conduit, and route away from moving parts or areas where high temperatures may occur.
- Connection of the supply voltage (V+) must be kept as close to the battery as possible.
- The power connection must be made with the 10 amp in-line fuse and fuse holder provided with the dock. Connect the fuse holder to the lead wire using the butt splice connectors provided with fuse holder. *When assembling the butt splice connectors use only Panduit crimp tools CT-100, CT-600, CT-1525 or CT-1551.*
The fuse holder location must be kept within 10 inches of the connection to the battery positive, away from moving parts, and temperatures that exceed 180 degrees F.
Caution: If the fuse holder requires replacement it should be replaced by qualified service personnel using Littlefuse part number FHM1 (Gamber-Johnson part number 11689). This device conforms to ASTM standard D471 and SAE standard J1128.
- Fuse must be inserted in supplied fuse holder. *Caution: For continued protection against risk of fire replace only with the same type and rating of supplied fuse. The provided fuse is rated at 10 amp, 32 volt AC/DC fast acting.*
- If a timing device is used follow the instructions of the manufacturer of that device. It must be wired in-line with the supply voltage (V+) to the docking station.
- If you have any installation questions, please call Gamber-Johnson customer support at 1-800-456-6868

Figure 2

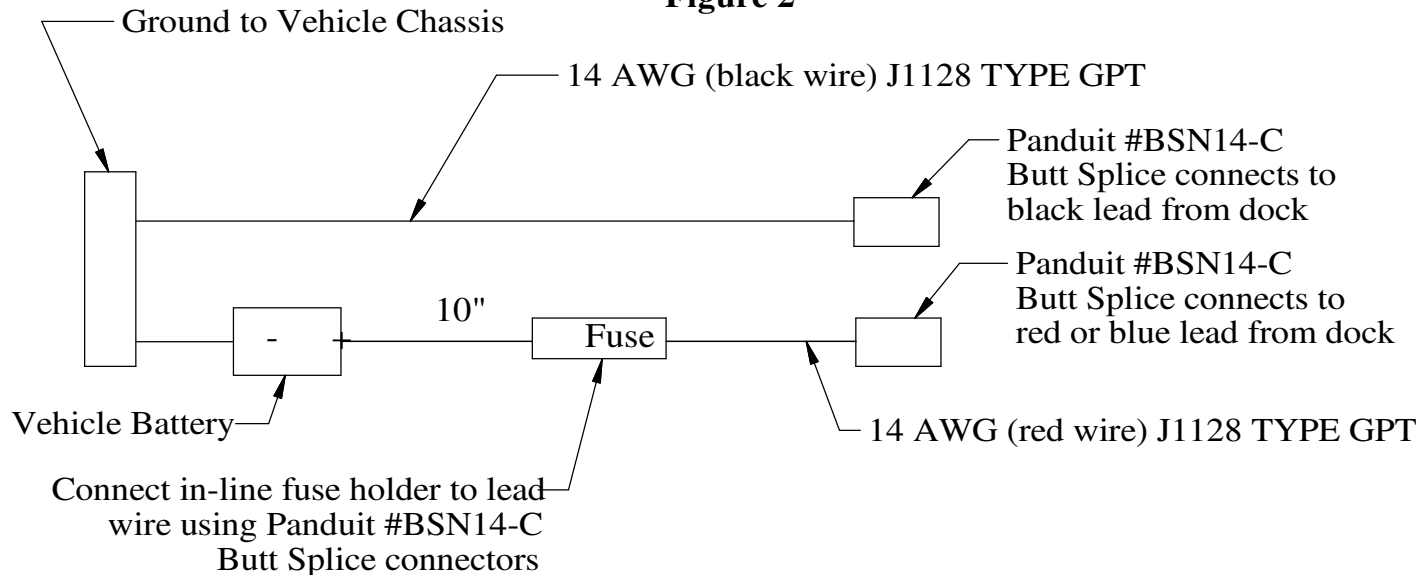

CABLE RESTRAINT INFORMATION

Retain the USB and Ethernet cables at the Support Bracket using the supplied cable ties.

USB/Ethernet Support Bracket

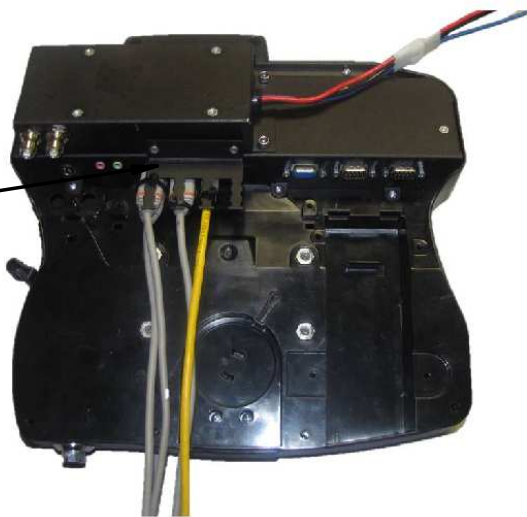
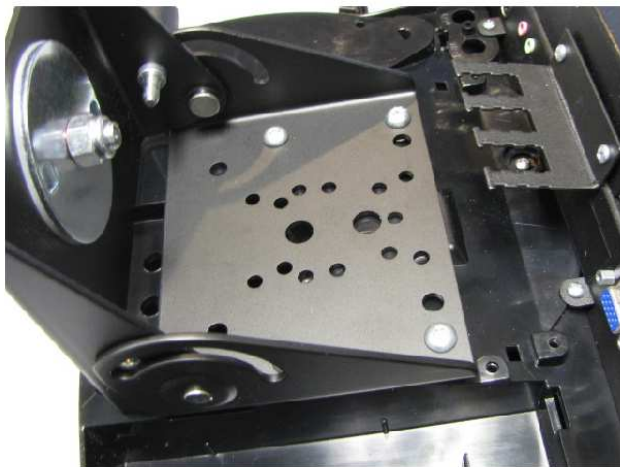

Figure 3

When attaching clevis to the dock make sure the orientation is as shown in Figure 3A. Otherwise clevis will interfere with support bracket and ports. If desired, handle can be switched to opposite side for convenience.

Figure 3A



DOCKING THE COMPUTER

1. Make sure the sliding door (located on the back of the computer) has been fully opened, exposing the computer's docking connector. (Figure 4)

2. Set computer in the dock:

- a. Hook the front of the computer on the front retainer (Figure 5).
- b. Lower the back of the computer onto the Alignment Pins (Figure 5).
- c. Lightly press down on the back of the computer to ensure it is fully seated.

3. Pull the docking handle towards the front of the dock until the latch catches (Figure 6). (The Push Button latch can be locked for added security)

4. Boot the computer. If the dock is powered, the computer is powered and ready for use.

**Docking station will operate with computer screen opened or closed.*



Figure 4

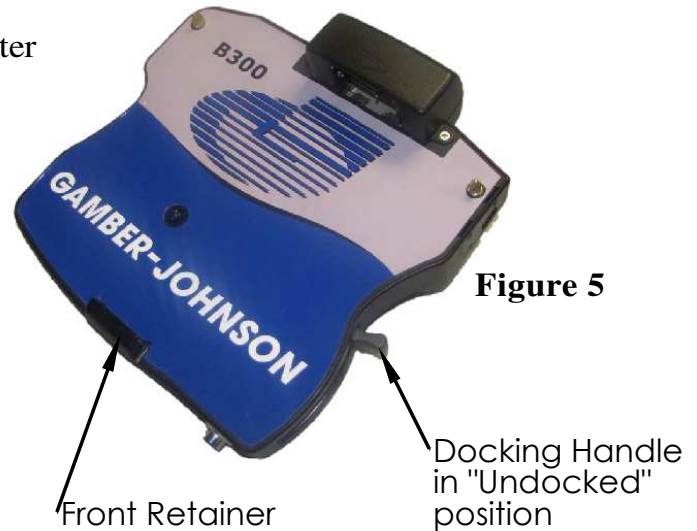

Figure 5



Figure 6

REMOVING COMPUTER FROM THE DOCK

1. Unlock with key if locked. Push button in until lever releases.
2. Lift the back of the computer off of the locating pins.
3. Lift the computer out from under the Front Retainer.

OPERATING on COMPUTER BATTERY POWER

Standard Installation (Power switch is operational) - If the DOCKING STATION power switch is turned off, removing power from the vehicle battery, the Green Switch LED will go out.

When the Green Switch LED is off , this indicates that the docking station is being powered by only the computer's battery. This feature allows for the docking station:

1. To be used for a limited time, depending on the computer's battery life.
2. To serve as a reminder to turn off the computer's power switch.

TROUBLESHOOTING

"Power" GREEN LED light does not light up:

If after applying power to the docking station and turning the power switch on, the GREEN LED light does not light up:

1. Check to see if the BLACK and RED (or BLUE in by-pass installation) wires are providing power to the docking station.
 - a. If NO - Determine the cause and solve.
 - b. If YES - The problem is inside the docking station and should not be adjusted by the installer. Please call Gamber-Johnson customer support at 1-800-456-6868.

CAUTION:** The docking connector has been designed to include "float" which allows for slight misalignment with the computer connector. The action of engaging the docking connector should be free and smooth. **Do not force the connectors to engage. You may damage the connector or the computer.